

Wirewound, Surface Mount Inductors



STANDARD ELECTRICAL SPECIFICATIONS						
IND. (nH)	TOL.	TEST FREQ. (MHz)	Q MIN.	SRF MIN. (MHz)	DCR MAX. (Ω)	RATED DC CURRENT ⁽¹⁾ (mA)
		L & Q				
1.0	0.3 nH, 0.2 nH	250	13	6000	0.045	1360
1.9	0.3 nH, 0.2 nH	250	16	6000	0.070	1040
2.0	0.3 nH, 0.2 nH	250	16	6000	0.070	1040
2.2	0.3 nH, 0.2 nH	250	18	6000	0.070	960
2.4	0.3 nH, 0.2 nH	250	16	6000	0.068	790
2.7	0.3 nH, 0.2 nH	250	16	6000	0.120	640
3.3	0.3 nH, 0.2 nH	250	20	6000	0.066	840
3.6	0.3 nH, 0.2 nH	250	20	6000	0.066	840
3.9	10%, 5%	250	20	6000	0.066	840
4.3	10%, 5%	250	18	6000	0.091	700
4.7	10%, 5%	250	15	4775	0.130	640
5.1	10%, 5%	250	23	5800	0.083	800
5.6	10%, 5%	250	23	5800	0.083	760
6.2	10%, 5%	250	23	5800	0.083	760
6.8	10%, 5%	250	20	4800	0.083	680
7.5	10%, 5%	250	25	5800	0.104	680
8.2	10%, 5%	250	25	4400	0.104	680
8.7	10%, 5%	250	18	4100	0.200	480
9.0	10%, 5%	250	25	4160	0.104	680
9.5	10%, 5%	250	18	4000	0.200	680
10	5%, 2%	250	23	3900	0.195	480
11	5%, 2%	250	26	3680	0.120	640
12	5%, 2%	250	26	3600	0.120	640
13	5%, 2%	250	24	3450	0.210	560
15	5%, 2%	250	26	3280	0.172	560
16	5%, 2%	250	24	3100	0.220	560
18	5%, 2%	250	25	3100	0.230	420
19	5%, 2%	250	26	3040	0.202	480
20	5%, 2%	250	25	3000	0.250	420
22	5%, 2%	250	25	2800	0.300	400
23	5%, 2%	250	26	2720	0.214	400
24	5%, 2%	250	25	2480	0.298	400
27	5%, 2%	250	26	2700	0.300	400
30	5%, 2%	250	25	2350	0.300	400
33	5%, 2%	250	24	2350	0.350	400
36	5%, 2%	250	26	2320	0.403	320
39	5%, 2%	250	25	2100	0.550	320
40	5%, 2%	250	26	2240	0.438	320
43	5%, 2%	250	25	2030	0.810	100
47	5%, 2%	200	26	2100	0.830	150
51	5%	200	25	1750	0.820	100
56	5%	200	22	1760	0.970	100
68	5%	200	22	1620	1.120	100
82	5%	150	20	1500	1.250	100
100	5%	150	20	1300	2.520	100
120	5%	150	20	1100	2.660	100

Note

(1) Value obtained when current flows and temperature has risen 15 °C

FEATURES

- Excellent solderability and resistance to soldering heat
- Suitable for reflow soldering
- High reliability and easy surface mount assembly
- Wide range of inductance values available
- Tape and reel packaging for automatic handling, 10 000/reel EIA 481
- Compliant to RoHS directive 2002/95/EC

RoHS
COMPLIANT

ELECTRICAL SPECIFICATIONS
Inductance Range: 1 nH to 47 nH

Operating Temperature: - 40 °C to + 125 °C

Storage Temperature: - 40 °C to + 125 °C

TEST EQUIPMENT

- Inductance is measured in HP4287A RF LCR meter with HP16193 fixture
- Q is measured in HP4287A RF LCR meter with HP16193 fixture
- SRF is measured in HP8753E RF network analyzer
- DCR is measured in HP4338B milliohmmeter

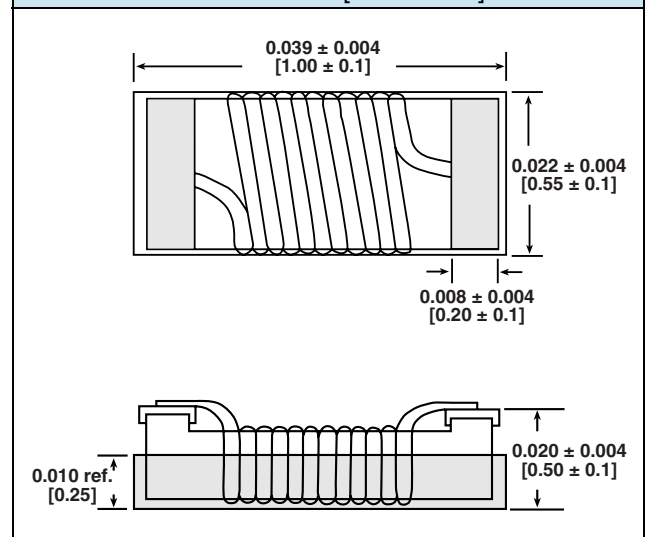
DIMENSIONS in inches [millimeters]

DESCRIPTION

IMC-0402-01	10 nH	± 5%	ER	e4
MODEL	INDUCTANCE VALUE	INDUCTANCE TOLERANCE	PACKAGE CODE	JEDEC LEAD (Pb)-FREE STANDARD

GLOBAL PART NUMBER

I	M	C	0	4	0	2	E	R	1	0	N	J	0	1
PRODUCT FAMILY			SIZE			PACKAGE CODE		INDUCTANCE VALUE			TOL.	SERIES		

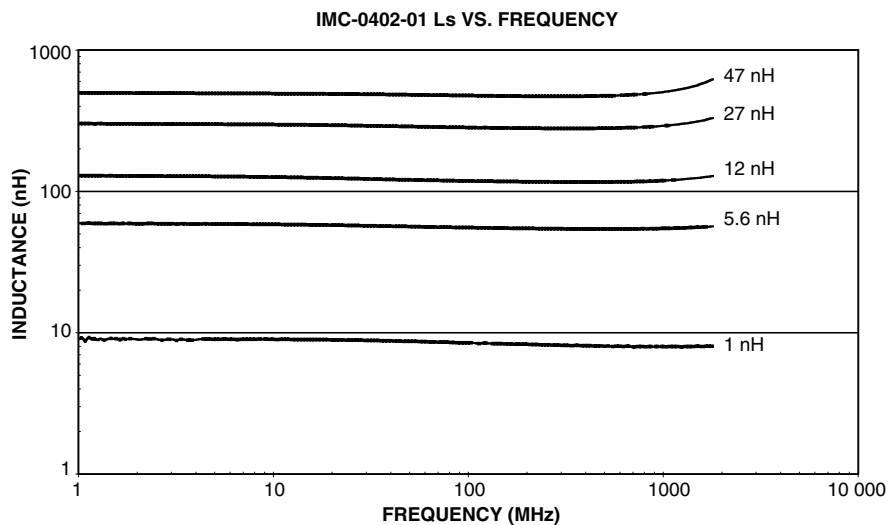
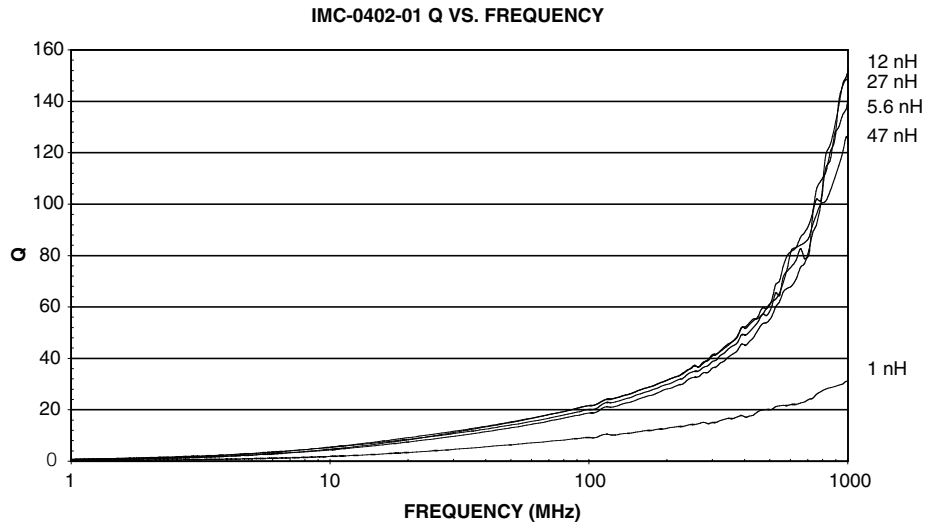
PERFORMANCE GRAPHS IMC-0402-01



TAPE AND REEL SPECIFICATIONS in inches [millimeters]

REEL DIMENSIONS

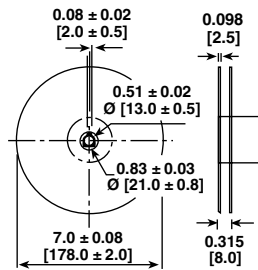

TAPE DIMENSIONS

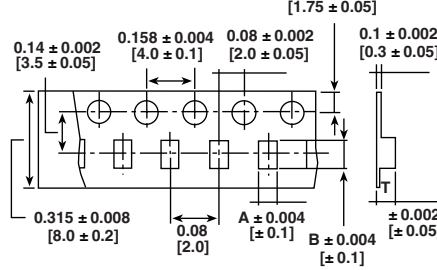

RECOMMENDED PATTERN

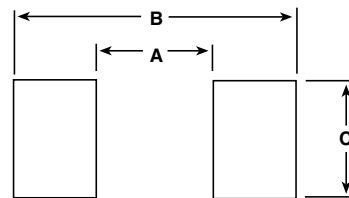

MODEL	UNITS PER REEL	MODEL	A	B	T	MODEL	A	B	C
IMC-0402-01	10 000	IMC-0402-01	0.028 [0.70]	0.047 [1.20]	0.028 [0.70]	IMC-0402-01	0.018 [0.45]	0.063 [1.60]	0.256 [0.65]



Disclaimer

All product specifications and data are subject to change without notice.

Vishay Intertechnology, Inc., its affiliates, agents, and employees, and all persons acting on its or their behalf (collectively, "Vishay"), disclaim any and all liability for any errors, inaccuracies or incompleteness contained herein or in any other disclosure relating to any product.

Vishay disclaims any and all liability arising out of the use or application of any product described herein or of any information provided herein to the maximum extent permitted by law. The product specifications do not expand or otherwise modify Vishay's terms and conditions of purchase, including but not limited to the warranty expressed therein, which apply to these products.

No license, express or implied, by estoppel or otherwise, to any intellectual property rights is granted by this document or by any conduct of Vishay.

The products shown herein are not designed for use in medical, life-saving, or life-sustaining applications unless otherwise expressly indicated. Customers using or selling Vishay products not expressly indicated for use in such applications do so entirely at their own risk and agree to fully indemnify Vishay for any damages arising or resulting from such use or sale. Please contact authorized Vishay personnel to obtain written terms and conditions regarding products designed for such applications.

Product names and markings noted herein may be trademarks of their respective owners.